

# Regulating damper

# DRU



## Dimensions

Ø 80–630

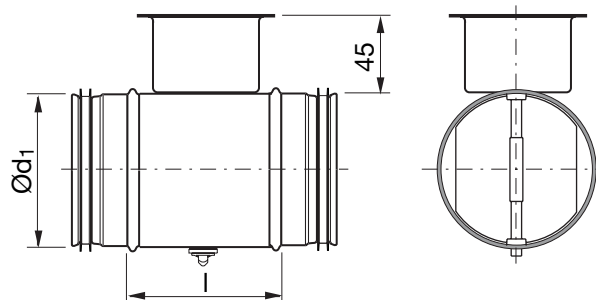

Ø 800–1000

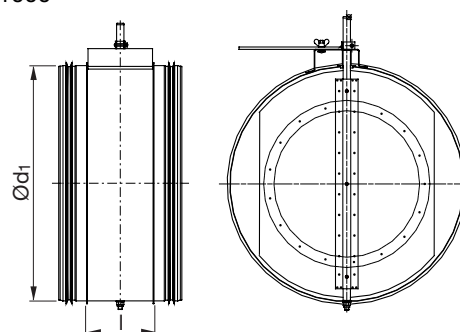

## Description

Has a turning, cut-off blade. The blade is stepless adjustable 0–90°. The damper admits an insulation thickness of approx. 50 mm.

The blade is designed to generate a minimum of noise. The noise is approx. the same as for a perforated blade. But the blade is less sensitive to clogging since it lacks perforations.

Setting angle  $\alpha$

$\alpha = 0^\circ =$  open blade,  $\alpha = 90^\circ =$  closed blade

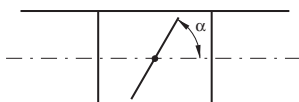

There is a separate assembly, measuring, balancing and maintenance instruction for this product.

Ø 80–1000 fullfills pressure class A in closed position.

The cup at Ø 80–630 can be complemented with the special insulation cup IK at insulation thicker than 50 mm.

## Reinforced blade

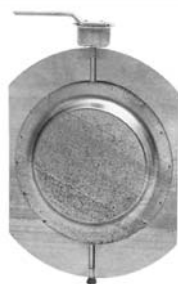

## Ordering example

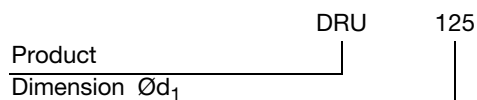

Ød <sub>1</sub> nom	l mm	m kg	Sealing class past closed blade
80	100	0,34	0
100	100	0,40	0
112	100	0,43	0
125	100	0,46	0
140	100	0,54	0
150	100	0,60	0
160	100	0,65	0
180	100	0,69	0
200	100	0,80	0
224	100	0,90	0
250	100	1,28	0
280	100	1,40	0
300	100	1,62	0
315	100	1,70	0
355	100	2,01	0
400	100	2,82	0
450	100	3,70	0
500	115	4,70	0
560	115	5,51	0
600	115	5,90	0
630	115	6,21	0
800	230	18,2	0
1000	230	24,4	0

# Regulating damper

# DRU

Property	Ø 80-315	Ø 400	Ø 500	Ø 630	Ø 800x1000
The blade is set via a knob in a protective cup.	x	x	x	x	
The setting of the blade is read against an embossed scale at the rim of the cup.	x	x	x	x	
The blade is locked with two screws, type Pozidriv (PZD2).	x	x	x	x	
The blade has reinforced locking with a sturdy wing nut.					x
The blade is reinforced.			x	x	
The blade is additionally reinforced.					x
With sturdy handle.		x	x	x	
With additionally reinforced handle.					x
With reinforced stop beads.			x	x	
The axle is reinforced.					x
The damper can be delivered prepared for motor.	x	x	x	x	
The damper can be delivered with motor.	x	x	x	x	x

## Technical data

Pressure drop graphs with noise data for dimensioning

The solid curves show the pressure drop,  $\Delta p_t$ , over the damper as a function of flow  $q$ , and setting angle  $\alpha$ . The dashed curves give the A-weighted sound power data,  $L_{WA}$ , in dB to the duct.

### Example

Given

Dimension Ø100  
Flow 60 l/s  
Pressure drop 200 Pa

Obtained from graph

Setting angle 40°  
Sound power level 63 dB (A)

Ø80

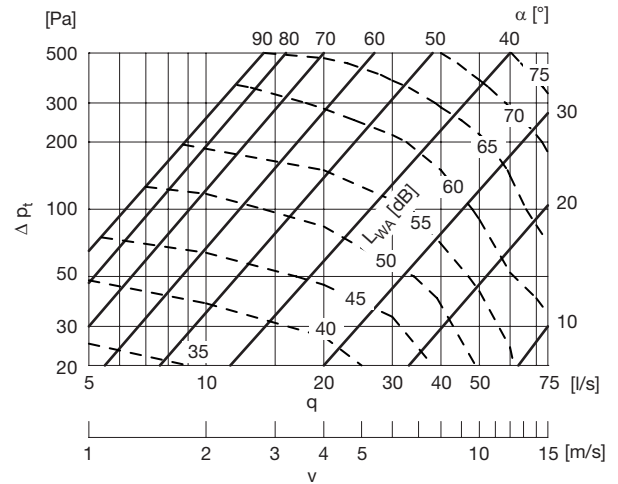

Ø100

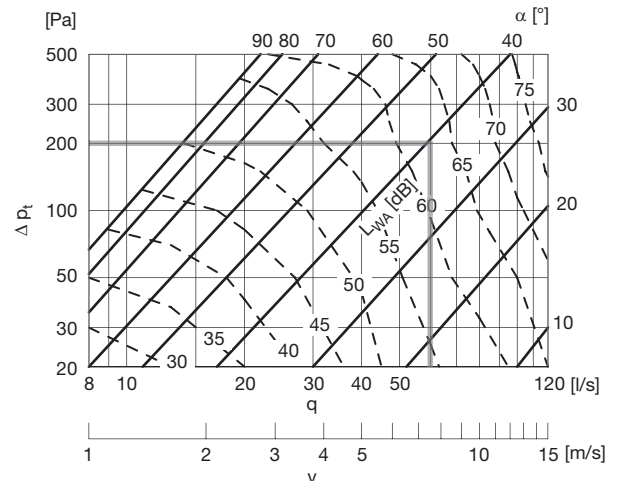

# Regulating damper

# DRU

- 1
- 2
- 3
- 4
- 5
- 6
- 7
- 8
- 9
- 10
- 11
- 12
- 13
- 14
- 15
- 16
- 17
- 18

Ø112

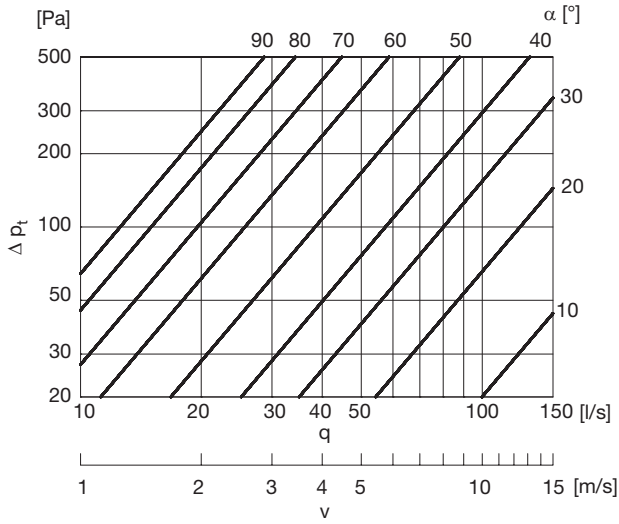

Ø150

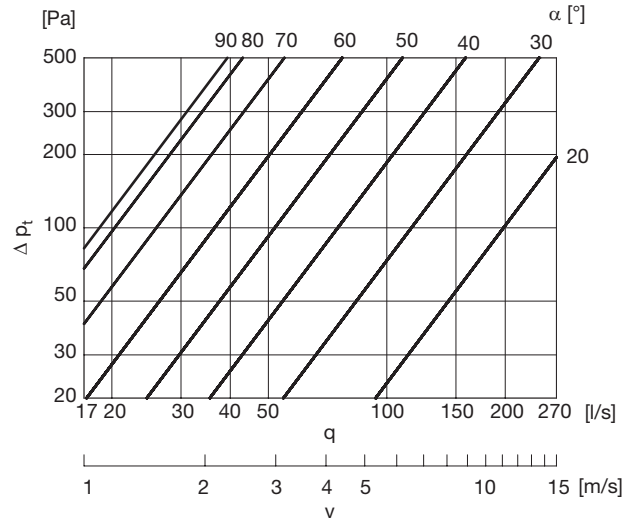

Ø125

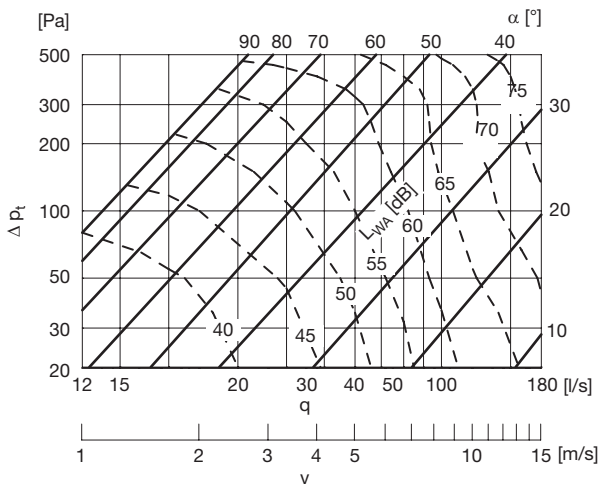

Ø160

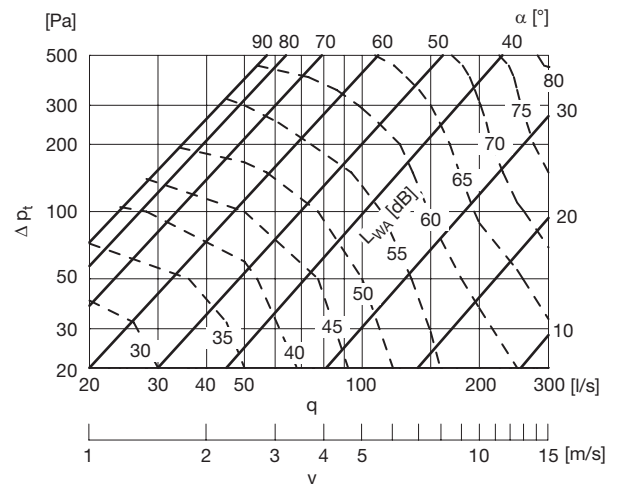

Ø140

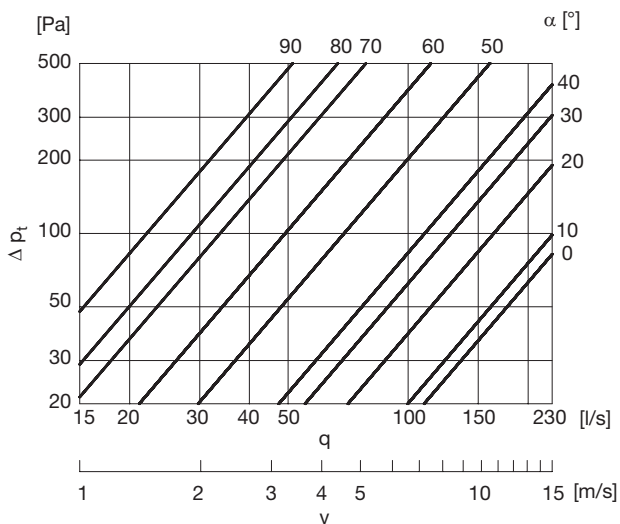

Ø180

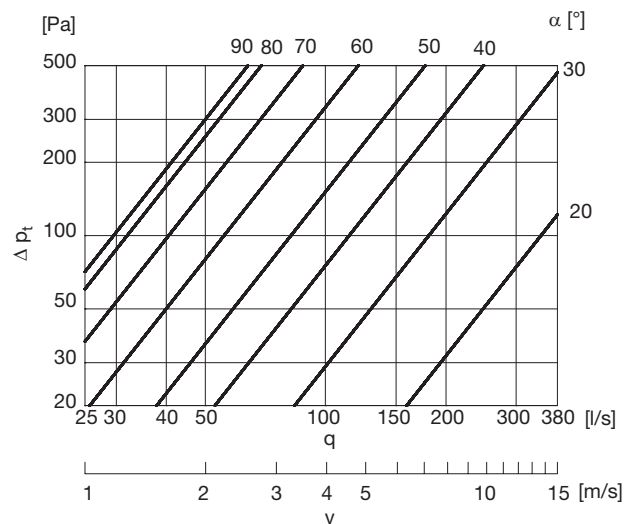

# Regulating damper

# DRU

Ø200

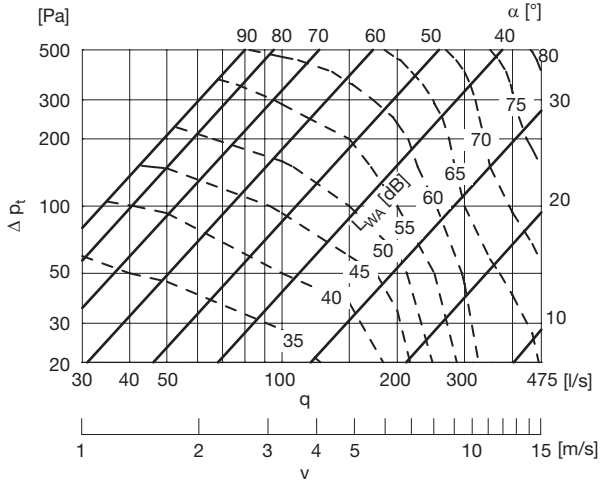

Ø280

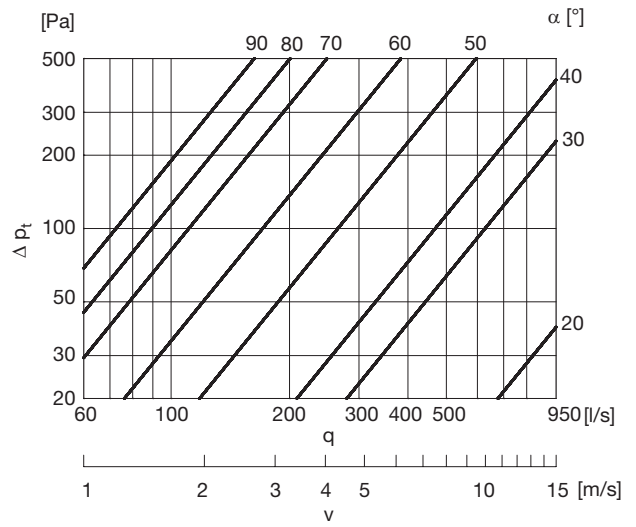

Ø224

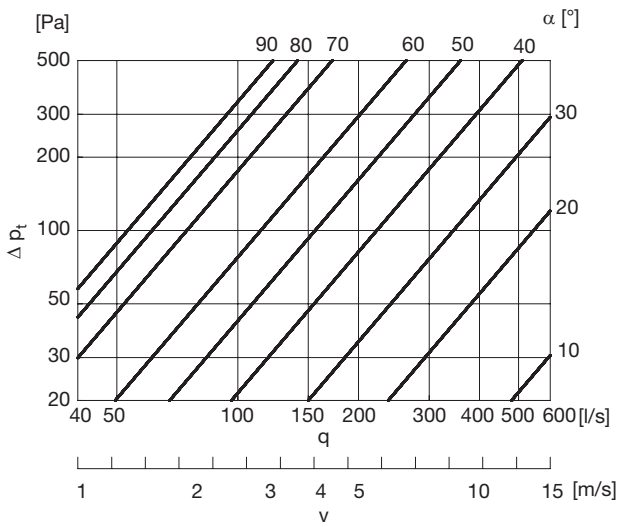

Ø300

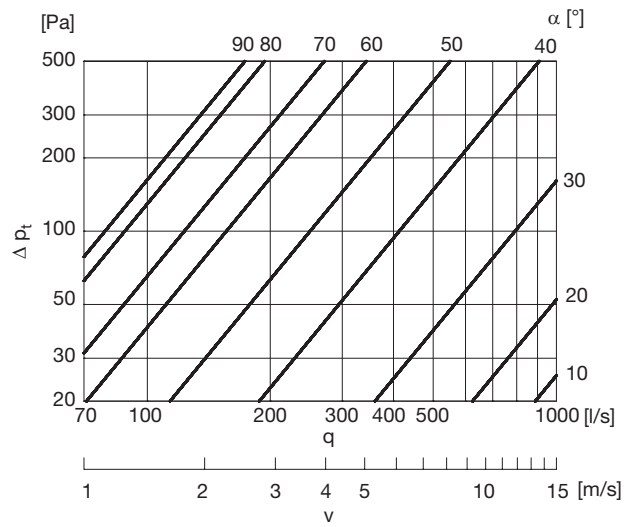

Ø250

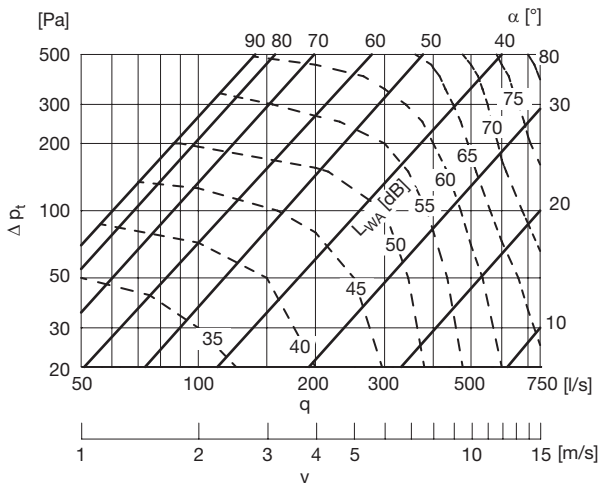

Ø315

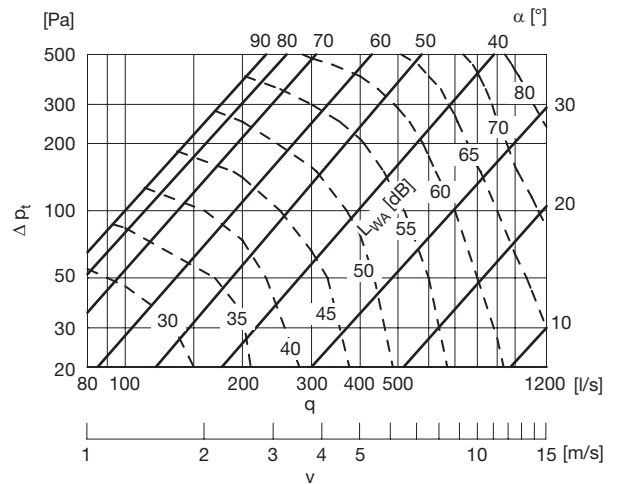

- 1
- 2
- 3
- 4
- 5**
- 6
- 7
- 8
- 9
- 10
- 11
- 12
- 13
- 14
- 15
- 16
- 17
- 18

# Regulating damper

# DRU

- 1
- 2
- 3
- 4
- 5
- 6
- 7
- 8
- 9
- 10
- 11
- 12
- 13
- 14
- 15
- 16
- 17
- 18

Ø355

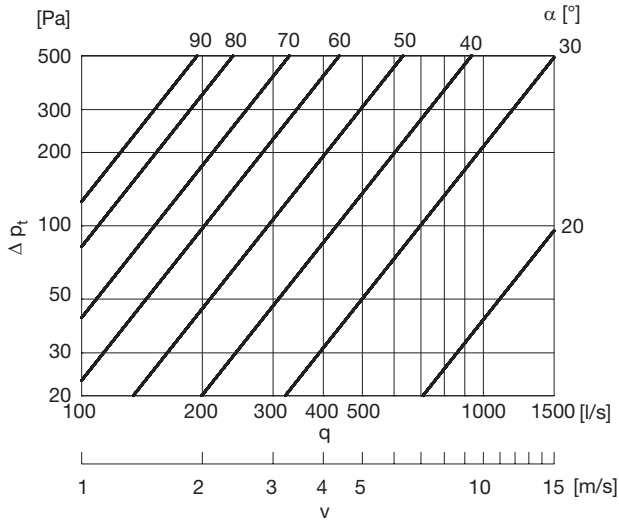

Ø500

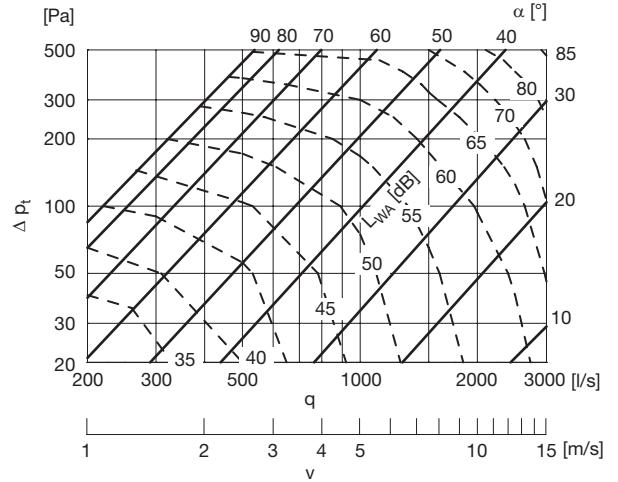

Ø400

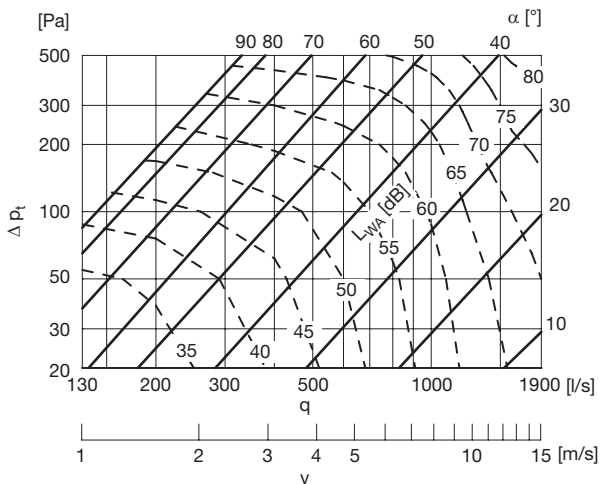

Ø560

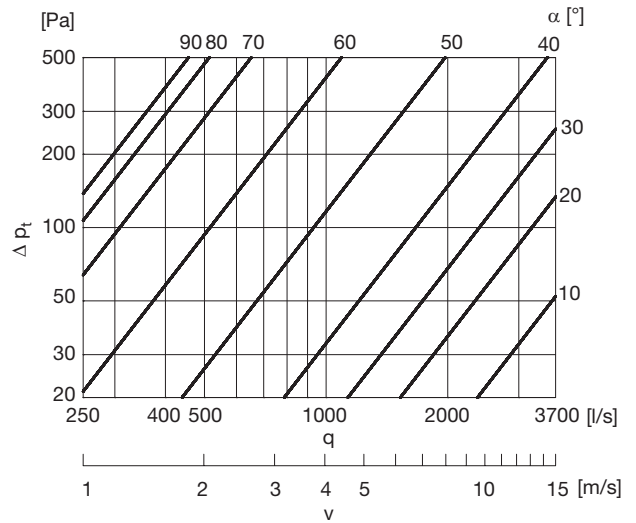

Ø450

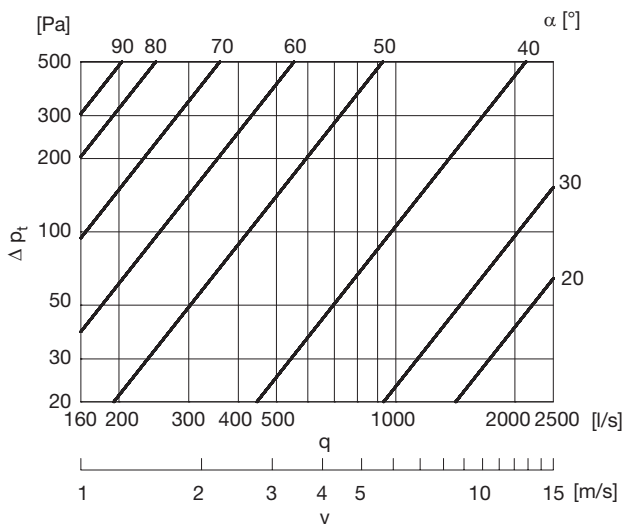

Ø600

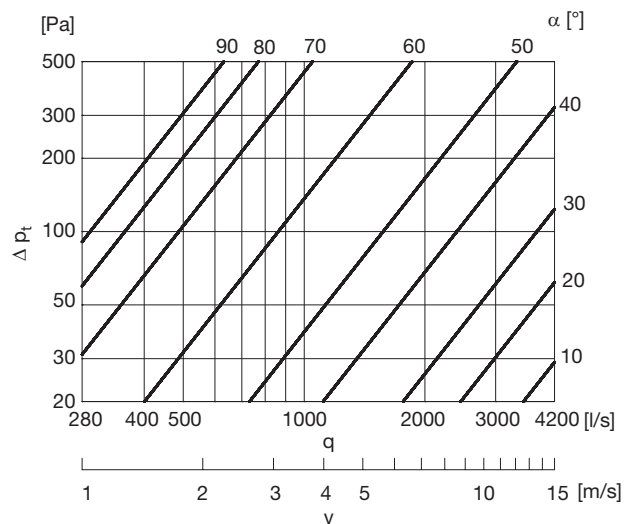

# Regulating damper

# DRU

Ø630

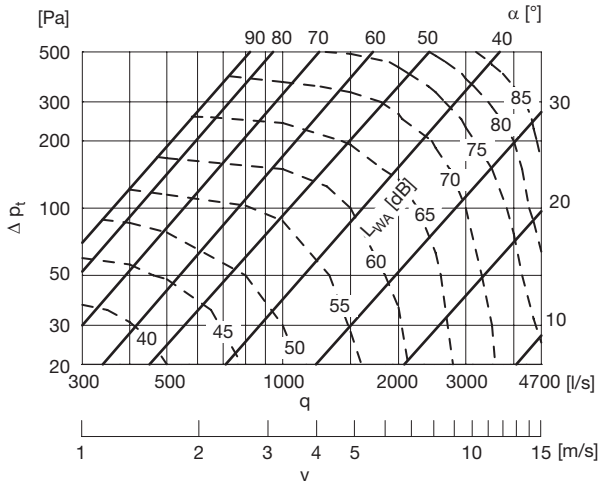

Ø900

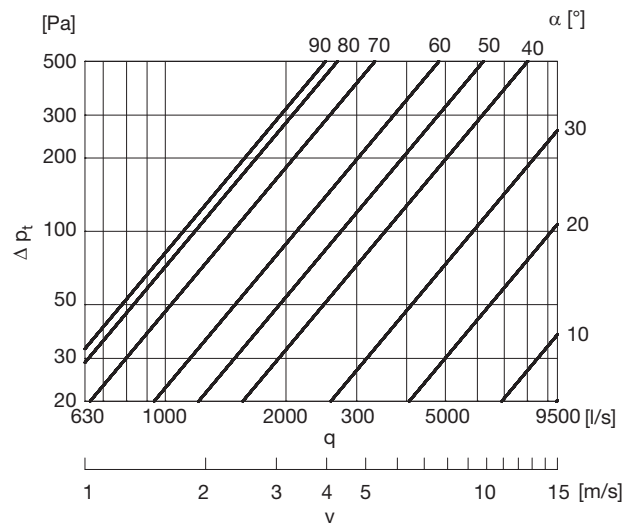

Ø710

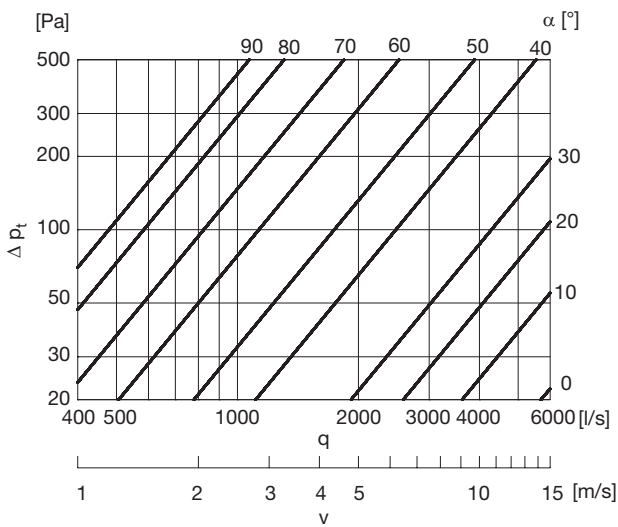

Ø1000

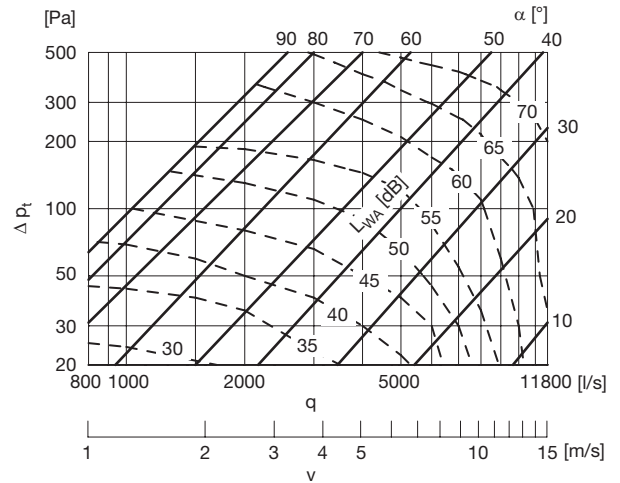

Ø800

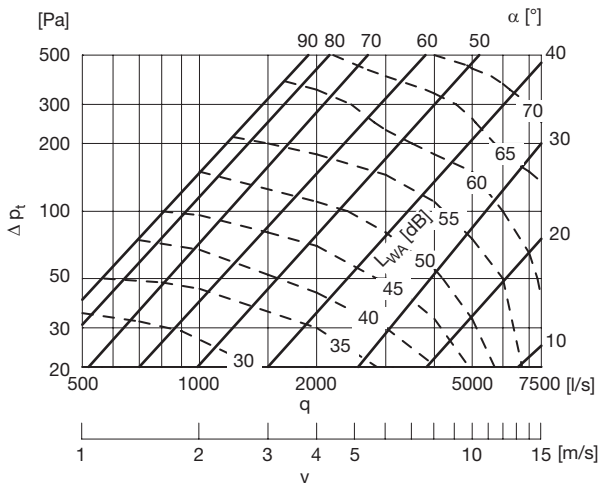

- 1
- 2
- 3
- 4
- 5
- 6
- 7
- 8
- 9
- 10
- 11
- 12
- 13
- 14
- 15
- 16
- 17
- 18



