

# Bend

# BU 60°

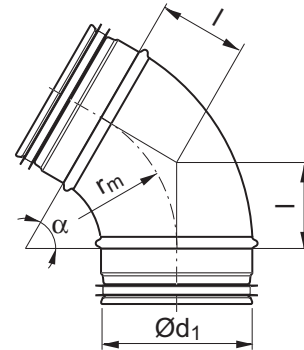

## Dimensions



$$r_m \approx 1 \cdot d_1$$

## Description

Pressed and seam welded bend.

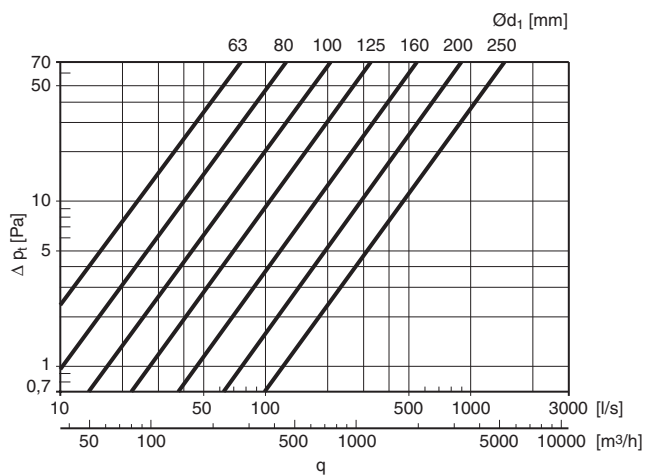

$\text{O}_{d_1}$ nom	l mm	m kg
63	64	0,30
80	58	0,32
100	58	0,33
112	69	0,37
125	72	0,33
140	78	0,51
150	87	0,50
160	92	0,56
180	104	0,79
200	115	0,82
224	130	0,95
250	144	1,12

## Ordering example

